

Motorized Pulley 165LS

Solid powerful drive for high use conveyors



Product description

Motorized pulley very robust and able to provide high torques and withstand high radial loads.

Characteristics

- Salt water resistant aluminum bearing housing
- Induction motor three phases alternating current
- Dual power supply
- Integral motor protection
- Steel- hardened helical spur gear
- Low noise operation
- Maintenance free
- Lifetime lubrication
- Reversible operation

Applications

- Conveyors for heavy and frequent use
- Logistics applications
- Airport and postal conveyors
- Warehouse loading conveyors
- Telescopic conveyors
- Agricultural plants
- Manufacturing of food processes
- Modular belts, steel or plastic applications
- Dry, damp and frequent wash applications

Technical data	
Motor data	
Type of Motor	Asynchronous squirrel-cage, IEC 34 (VDE 0530)
Insulation class of motor windings	Class F, IEC 34 (VDE 0530)
Derated windings (20% power reduction)	On request for applications without belt
Voltage	230/400 V \pm 5% (IEC 34/38) Special voltage on request
Frequency	50/60 Hz
Internal shaft sealing system	Double-lipped FPM or nitrile rubber, NBR
Protection rate	IP66
Thermal protection	Bimetallic Contact
Ambient temperature, 3-phase motor	-25 to +40 °C
General technical data	
Max. Roller length (RL)	1800 mm

All data and values declared in the catalogue refer to operation with a frequency of 50 Hz.





Motorized Pulley 165LS

Solid powerful drive for high use conveyors

Materials

The following Motorized Pulley components are available in different versions, as shown in the below chart, with further options for the material type as indicated.

Components	Version	Materiale				
		Aluminium	Steel	Stainless steel	Brass/Nickel	Polymer
Shell	Crowned		Std	TS8N		
	Cylindrical		Std	TS8N		
	Cylindrical + key (for sprockets)		Std	TS8N		
	Special crowns and grooves		Std	TS8N		
End housing	Standard	Std		TS8N		
	With V-grooves		Std	TS8N		
	With O-grooves		Std	TS8N		
	With chain sprockets		Std	TS8N		
Shaft	Standard		Std	TS8N		
	Cross-drilled and threaded, M10		Std	TS8N		
Electrical connection	Straight connector			TS8N	Std	
	Elbow connector			TS8N		Std
	Terminal box	Std		TS8N		

Please contact Rulmeca for further versions.

TS8N Version - End Caps in stainless steel with PTFE lip seals.

Options

- Rubber Lagging for standard belts
- Profiled lagging for plastic modular belts
- Profiled lagging for thermoplastic belts
- Sprockets for plastic modular belts
- Backstop / Anti run-back bearings
- Electromagnetic brake
- Rectifiers
- Encoder
- Food-grade Oil (EU, FDA and USDA)
- Non-horizontal mounting (more than $\pm 5^\circ$)
- Dual speed motor
- Version TS7N - as TS8N but with re-greasable labyrinth seals

Note: The combination of encoder and electromagnetic brake is not possible.

Accessories

- Mounting brackets
- Idler Pulleys
- Rollers for conveyors
- Frequency Converters

Motorized Pulley 165LS

Solid powerful drive for high use conveyors



Technical data for motorized pulley 165LS - 3 phase - 50Hz

Rated power [kW]	Poles n.	Gear stages n.	Gear ratio i	Rated speed of the shell [m/s]	Rated revolutions of the shell [min ⁻¹]	Rated torque of Motorized pulley [Nm]	Rated tangential force [N]	Max. belt tension T1+T2 [N]	Min. length RL [mm]	
0,37	6	3	61,56	0,13	14,9	236	2865	19000	400	
			49,75	0,16	18,5	194	2350			
	4	3	61,56	0,20	22,3	158	1910	11000	350	
			49,75	0,25	27,6	128	1545			
			37,93	0,32	36,3	97	1175			
			30,05	0,40	45,8	77	930			
			23,76	0,50	57,9	61	735			
			19,20	0,63	71,6	49	595			
			14,64	0,80	93,9	38	455			
			11,60	1,00	118,5	30	360			7600
0,75	6	3	46,23	0,16	20,4	340	4100	19000	400	
	4	3	61,56	0,20	22,8	304	3685	11000	400	
			49,75	0,25	28,2	246	2980			
			37,93	0,32	37,0	187	2270			
			30,05	0,40	46,8	148	1800			
		2	23,76	0,50	59,1	117	1425			
			19,20	0,63	73,2	95	1150			
			14,64	0,80	96,0	72	880			
			11,60	1,00	121,1	57	695			7600
	1,10	4	3	46,23	0,25	30,7	325	3940	11000	400
37,93				0,32	37,4	267	3230			
2		2	61,56	0,40	46,0	222	2695	11000	400	
			49,75	0,50	56,9	180	2180			
			37,93	0,63	74,6	137	1660			
			30,05	0,80	94,2	108	1315			
		2	23,76	1,00	119,1	86	1040		7600	400
			19,20	1,25	147,4	69	840			
			14,64	1,60	193,3	53	640			400
			11,60	2,00	244,0	42	510			
1,50	2	3	46,23	0,50	61,6	237	2880	11000	400	
			37,93	0,63	75,1	195	2360			
			30,05	0,80	94,8	154	1870			
		2	23,76	1,00	119,9	121	1465	7600	400	
			19,20	1,25	148,4	98	1185			
			14,64	1,60	194,7	74	900		400	
			11,60	2,00	245,7	59	715			
			9,43	2,50	302,2	48	580			
7,80	3,15	365,4	40	480	7100	400				



Motorized Pulley 165LS

Solid powerful drive for high use conveyors

Technical data for Motorized pulley 165LS - 3phase - 50Hz

Rated power [kW]	Poles n.	Gear stages n.	Gear ratio i	Rated speed of the shell [m/s]	Rated revolutions of the shell [min ⁻¹]	Rated torque of Motorized pulley [Nm]	rated tangential force [N]	Max. belt tension T1+T2 [N]	Min. length RL [mm]
2,20	2	3	46,23	0,50	61,9	330	3990	11000	430
			37,93	0,63	75,4	270	3280		
			30,05	0,80	95,2	215	2600		
			12,43	1,00	230,1	175	2110		
		2	7600	20,21	1,25	141,5	145	1750	430
				14,64	1,60	195,4	105	1270	
				11,60	2,00	246,6	84	1010	
				9,43	2,50	303,3	68	820	
7,80	3,15	366,7	55	675	7100	430			

Standard weights for Motorized pulley 165LS

Rated power [kW]	Poles n.	Standard weight [kg] for standard RL [mm]													
		350	400	450	500	550	600	650	700	750	800	850	900	950	1000
0,37	6	---	30,0	31,5	33,0	34,0	35,0	36,0	37,5	39,0	40,0	41,0	42,5	44,0	45,0
	4	26,0	28,0	29,5	31,0	32,0	33,0	34,0	35,5	37,0	38,0	39,0	40,5	42,0	43,0
0,75	6	---	33,0	34,5	36,0	37,0	38,0	39,0	40,5	42,0	43,0	44,0	45,5	47,0	48,0
	4	---	31,0	32,5	34,0	35,0	36,0	37,0	38,5	40,0	41,0	42,0	43,5	45,0	46,0
1,10	4	---	34,0	35,5	37,0	38,0	39,0	40,0	41,5	43,0	44,0	45,0	46,5	48,0	49,0
	2	---	33,0	34,5	36,0	37,0	38,0	39,0	40,5	42,0	43,0	44,0	45,5	47,0	48,0
1,50	2	---	34,0	35,5	37,0	38,0	39,0	40,0	41,5	43,0	44,0	45,0	46,5	48,0	49,0
2,20	2	---	37,0	37,5	38,0	39,0	40,0	41,0	42,5	44,0	45,0	46,0	47,5	49,0	50,0

Motorized Pulley 165LS

Solid powerful drive for high use conveyors



Cable Specification

Available cable options:

- Standard, screened
- Standard, unscreened
- Halogen-free, screened
- Halogen-free, unscreened

Available lengths: 1 / 3 / 5 m.

Min.Length with Option

The following options increase the minimum length of the motorized pulley.

Option	RL min. with option mm
Brake	RL min. + 50 mm
Encoder SKF	RL min. + 0 mm
Encoder RLS	RL min. + 50 mm



Motorized Pulley 165LS

Solid powerful drive for high use conveyors

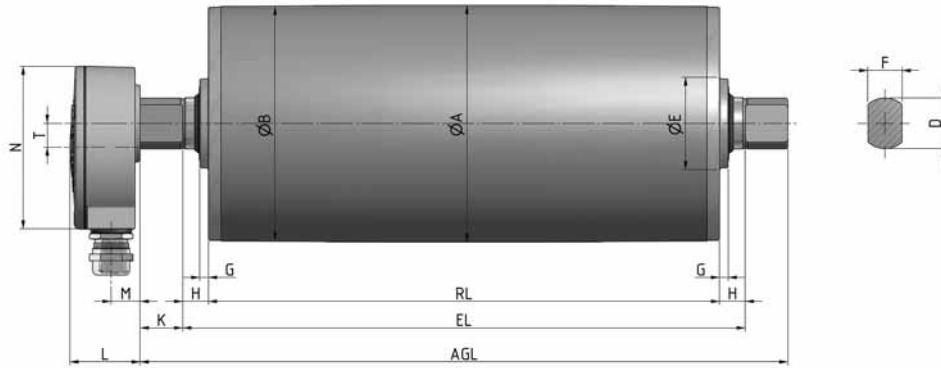

Motorized pulley standard version with Terminal box in aluminium.

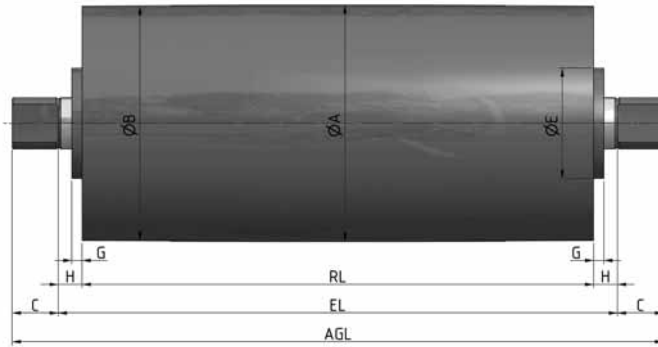

Idler pulley in stainless steel (TS).

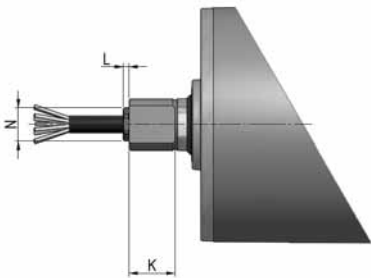

Straight connector in brass or in stainless steel.

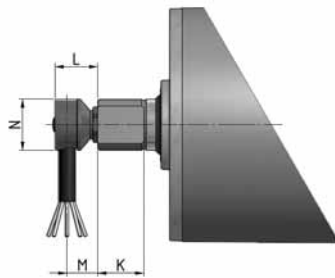

Elbow connector in stainless steel.

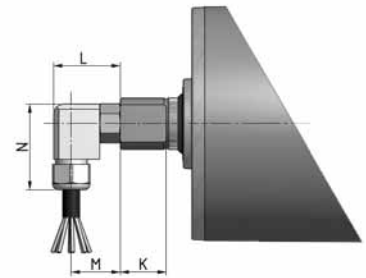

Elbow connector in polyamide.

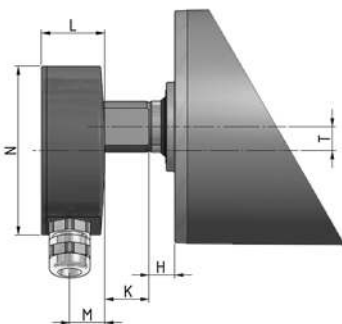

Terminal box in stainless steel.

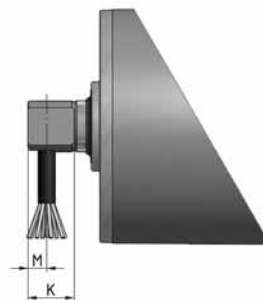

Cable connector 90° with threaded shaft.

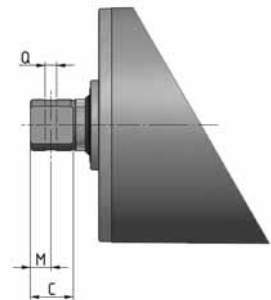

Shaft, cross-drilled and threaded.

Motorized Pulley 165LS

Solid powerful drive for high use conveyors



Type/Option	A mm	B mm	C mm	D mm	E mm	F mm	G mm	H mm	K mm	L mm	M mm	N mm	Q mm	T mm
Motorized Pulley 165LS Standard version with Terminal Box in Aluminium	165	163,5	45	40	80	30	10	20	45	41	17	95		14
Terminal Box in Stainless steel									45	37	20,5	99		14
Idler Pulley in stainless steel (TS)					64,5		8		47					
Straight connector in brass or stainless steel									47	4		27		
Elbow connector in stainless steel									47	25	18	30		
Elbow connector in Polyamide									47	39	29	50		
Cable Connector 90° with threaded shaft									47		8-11			
Cross-drilled and threaded shaft									47		23,5		M10	