

Motorized Pulley 80LP

A strong capable drive
for small light duty conveyors

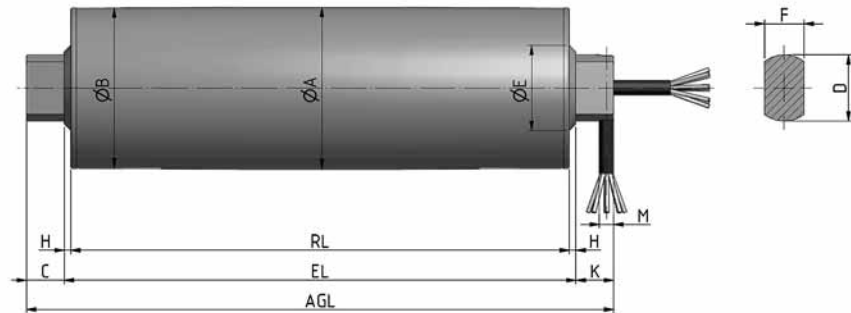

Motorized Pulley Standard Version.

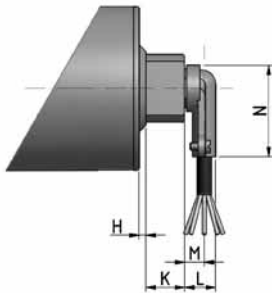

Elbow connector in aluminium.

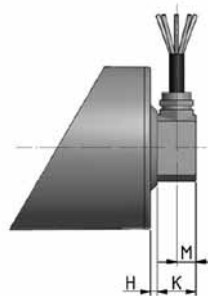

Cable connection 90°.

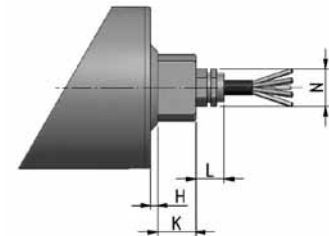

Straight connector.

Type/Option	A mm	B mm	C mm	D mm	E mm	F mm	G mm	H mm	K mm	L mm	M mm	N mm	Q mm	T mm
Motorized Pulley Standard Version	85,5	84,5	20	35	45	21		3	20		8			
Elbow connector in aluminium									20	18	12	48		
Cable connection 90 °									20		10			
Straight Connector									20	15		20		

Std. RL shell lengths (mm)	300	350	400	450	500	550	600	650	700	750	800	850	900
Avrg. weighth (kg)	4,3	4,5	4,7	4,9	5,1	5,3	5,5	7,6	8	8,3	8,6	9	9,3

- Min lengths: see table at pag.12
- Max length: 900 mm
- Weights are orientative due to different shell executions and motor powers



Motorized Pulley 80LS

A very compact strong drive for small high use conveyors

Product description

This Motorized Pulley is perfect for high torque applications with limited space or access.

Characteristics

- Salt water resistant aluminum bearing housings
- Three phase AC induction motor
- 3-phase dual voltage is standard
- Integral motor protection
- Hardened steel helical gear box
- Low noise operation
- Maintenance free
- Lifetime lubrication
- Reversible operation
- Reinforced internal shaft for RL exceeding 500 mm

Applications

- Small conveyors for feeding materials with frequent cycle
- Packaging equipment
- Dynamic weighing equipment
- Metal detectors
- Ideal for pharmaceutical industry
- Meat processing
- Steel or plastic modular belts applications
- Dry, humid and wash down applications

Technical data	
Motor Data	
Type of Motor	Asynchronous squirrel-cage, IEC 34 (VDE 0530)
Insulation class of motor windings	Class F, IEC 34 (VDE 0530)
Derated windings (20% power reduction)	On request for applications without belt
Voltage	230/400 V \pm 5% (IEC 34/38) Special voltage on request
Frequency	50/60 Hz
Internal shaft sealing system	Double-lipped, FPM OR nitrile rubber NBR
Protection rate	IP66
Thermal protection	Bimetallic Contact
Ambient temperature, 3-phase motor	0°C to +40 °C
General technical data	
Max. Roller length (RL)	1000 mm

All data and values declared in the catalogue refer to operation with a frequency of 50 Hz.



Motorized Pulley 80LS

A very compact strong drive for small high use conveyors



Materials

The following Motorized Pulley components are available in different versions, as shown in the below chart, with further options for the material type as indicated.

Component	Version	Material				
		Aluminium	Steel	Stainless steel	Brass/Nickel	Polymer
Shell	Crowned		Std	TS8N		
	Cylindrical		Std	TS8N		
	Cylindrical + key (for sprockets)		Std	TS8N		
	Special crowns and grooves		Std	TS8N		
End housing	Standard	Std		TS8N		
	With V-grooves			TS8N		
	With O-grooves			TS8N		
Shaft	Standard			Std		
	Cross-drilled and threaded, M6			Std		
Electrical connection	Straight connector			TS8N	Std	
	Elbow connector			TS8N		Std
	Terminal box*	Std		TS8N		

* Shaft cap version .

Please contact Rulmeca for further versions.

TS8N Version - End Caps in stainless steel with PTFE lip seals.

Options

- Rubber Lagging for standard belts
- Profiled lagging for plastic modular belts
- Profiled lagging for thermoplastic belts
- Sprockets for plastic modular belts
- Backstop / Anti run-back bearing
- Electromagnetic brake
- Rectifiers
- Encoder
- Food-grade Oil (EU, FDA and USDA)
- Non-horizontal mounting (more than $\pm 5^\circ$)

Note: The combination of encoder and electromagnetic brake is not possible.

Accessories

- Mounting brackets
- Idler Pulleys
- Rollers for conveyors
- Shaft cap
- Frequency Converters



Motorized Pulley 80LS

A very compact strong drive for small high use conveyors

Technical data for Motorized Pulley 80LS - 3-phase - 50Hz

Rated Power [kW]	Poles n.	Gear Stages n.	Gear Ratio i	Rated speed of the shell [m/s]	Rated revolutions of the shell [min ⁻¹]	Rated torque of Motorized pulley [Nm]	Rated tangential force [N]	Max. belt tension T1+T2 [N]	Min. Length RL [mm]
0,02	8	3	53,89	0,05	11,3	16,0	391	3600	250
			37,78	0,07	16,1	11,2	274		
			30,88	0,08	19,8	9,2	224		
0,035	4	3	53,89	0,11	25,0	12,7	310	3600	200
			37,78	0,14	35,7	8,9	217		
			30,88	0,18	43,7	7,3	177		
		2	21,23	0,25	63,5	5,0	122	2650	
			14,88	0,38	90,6	3,5	86		
			12,16	0,45	110,8	2,9	70		
0,07	4	3	53,89	0,10	23,9	26,6	648	3600	250
			37,78	0,14	34,1	18,6	454		
			30,88	0,18	41,7	15,2	371		
		2	21,23	0,25	60,7	10,5	255	2650	
			14,88	0,38	86,5	7,3	179		
			12,16	0,45	105,9	6,0	146		
	2	3	53,89	0,22	51,5	12,3	301	2650	200
			37,78	0,32	73,5	8,6	211		
			30,88	0,38	90,0	7,1	172		
		2	21,23	0,55	130,8	4,9	118	2100	
			14,88	0,80	186,6	3,4	83		
			12,16	1,00	228,4	2,8	68		
0,12	2	3	53,89	0,22	51,5	21,1	515	2650	250
			37,78	0,32	73,5	14,8	361		
			30,88	0,38	90,0	12,1	295		
		2	21,23	0,55	130,8	8,3	203	2100	
			14,88	0,80	186,6	5,8	142		
			12,16	1,00	228,4	4,8	116		

Motorized Pulley 80LS

A very compact strong drive for small high use conveyors



Standard weights for Motorized Pulley 80LS

Rated Power [kW]	Poles n.	Standard weight [kg] for standard RL [mm]													
		200	250	300	350	400	450	500	550	600	650	700	800	900	1000
0,02	8	---	3,40	3,85	4,30	4,75	5,20	5,65	6,10	6,55	7,00	7,45	7,90	8,35	8,80
0,035	4	2,80	3,25	3,70	4,15	4,60	5,05	5,50	5,95	6,40	6,85	7,30	7,75	8,20	8,65
0,07	4	---	3,40	3,85	4,30	4,75	5,20	5,65	6,10	6,55	7,00	7,45	7,90	8,35	8,80
	2	2,80	3,25	3,70	4,15	4,60	5,05	5,50	5,95	6,40	6,85	7,30	7,75	8,20	8,65
0,12	2	---	3,40	3,85	4,30	4,75	5,20	5,65	6,10	6,55	7,00	7,45	7,90	8,35	8,80

Cable specification

Available cable options:

- Standard, Screened
- Standard, Unscreened
- Halogen-free, Unscreened

Available lengths: 1/3/5 m.

Min. length with option

The following options increase the minimum length of the motorized pulley.

Option	RL min with option
Electromagnetic brake	RL min. + 50 mm
Encoder	RL min. + 0 mm



Motorized Pulley 80LS

A very compact strong drive for small high use conveyors

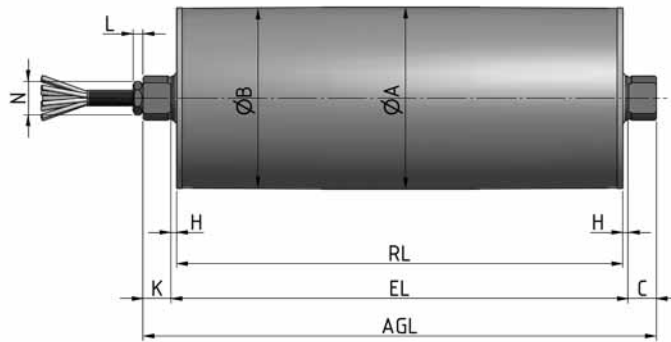

Standard Motorized Pulley with straight connector in stainless steel.

Shaft Cap.

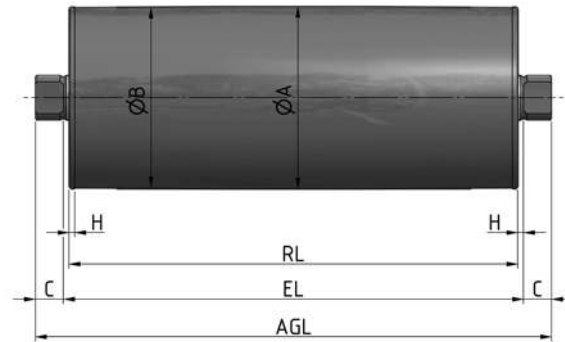

Idler Pulley, stainless steel version (TS8N).

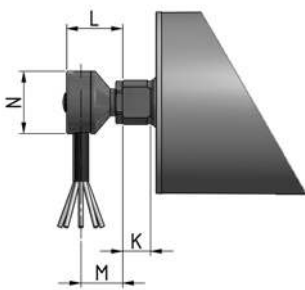

Elbow connector in stainless steel.

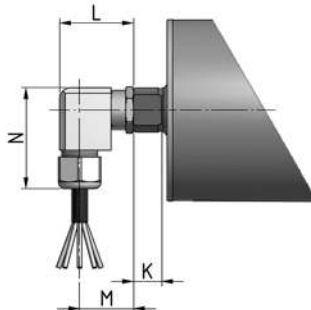

Elbow Connector in polyamide.

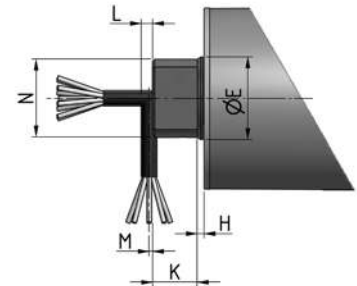

Straight/Elbow connector with shaft cap in stainless steel.

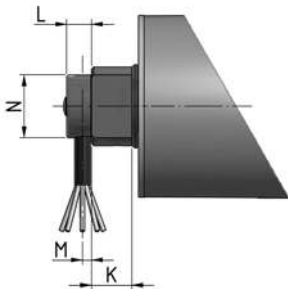

Elbow connector with shaft cap in stainless steel.

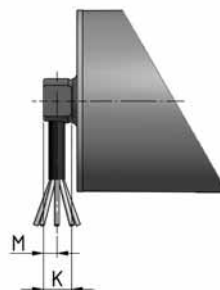

Cable Connector 90° with threaded shaft.

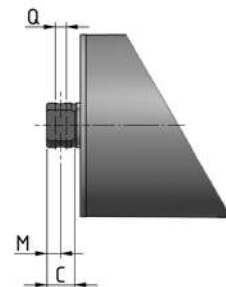

Cross-drilled and threaded shaft.

Motorized Pulley 80LS

A very compact strong drive for small high use conveyors



Type/Option	A mm	B mm	C mm	D mm	E mm	F mm	G mm	H mm	K mm	L mm	M mm	N mm	Q mm	T mm
Motorized pulley 80LS Standard version														
Straight connector in stainless steel	81,5	80,5	12,5	20		14		2,5	12,5	4,5		15		
Elbow connector in stainless steel									12,5	25	18,5	28		
Elbow connector in Polyamide									12,5	33	24	45		
Cable Connector 90° with threaded shaft									12,5		6			
Cross-drilled and threaded shaft									12,5		6,25		M6	
Straight/Elbow Connector with shaft cap in Stainless Steel			20	35	37	21		3	20	5	1,5	35		
Elbow Connector with shaft cap in Stainless Steel									18	11	4	28		